



PALE FRANGISOLE
SUNSCREEN BLADES

B.B.C.[®]
MV Line Group

SISTEMI PALE FRANGISOLE

SUNSCREEN BLADES

Un sistema efficace che consente il filtraggio della luce negli ambienti, il controllo ottimale della temperatura degli interni garantendo, in qualunque stagione, condizioni climatiche ideali.

La gamma di profili e accessori offre la possibilità di soddisfare qualsiasi esigenza architettonica.

Il sistema a pale fisse consente di realizzare schermature con pale ad inclinazione stabilita. Le pinze (disegnate per sostenere pale da 200 mm di corda) offrono un ampio campo di regolazione e versatilità nell'installazione.

Il sistema a pale orientabili composto da profilo montante, asta di movimentazione e pale di diversa sezione (per coprire le diverse richieste architettoniche e/o strutturali), risulta semplice e veloce nell'installazione. L'assemblaggio delle pale ai montanti, il collegamento dell'asta di movimentazione ai tappi terminali non richiede lavorazioni di foratura a passo; grazie alle apposite "cave a T" di cui sono dotati i montanti e l'asta di collegamento, l'interasse può essere variato a seconda delle esigenze utilizzando elementi di viteria standard in acciaio inox. Le operazioni di preparazione e di installazione risultano notevolmente semplificate.

Le pale di forma ellissoidale sono disponibili con lunghezze di corda da: 150 - 200 - 300* - 400* - 500* e 600* mm.

*Le sezioni da 300 mm fino a 600 mm sono componibili.

L'orientamento delle pale può essere gestito sia manualmente (forcella a snodo pesante) che elettricamente (attuatore elettrico). L'angolo massimo di apertura delle pale è di 140°.

Il sistema frangisole a lamelle fisse offre la possibilità di creare protezione e aerazione di ambienti tecnici, vani scala o laddove privacy e comfort sono richiesti.

Unità di controllo

Disponibile per la movimentazione elettrica una centralina in grado di comandare fino a 4 attuatori, singolarmente e contemporaneamente. Il controllo può essere fatto mediante telecomando e/o pulsante.

La centralina è in grado di gestire i sensori: vento, pioggia e luminosità.

An effective system that allows light to be filtered into the rooms and optimal indoor temperature control, thereby assuring ideal climatic conditions in any season.

The range of profiles and accessories offers the possibility of meeting any architectural need.

The fixed blade system allows screening to be installed with blades at a set inclination. The clamps (designed to support 200 mm chord length blades) offer a wide adjustment range and versatility in installation.

The adjustable blade system consisting of an upright profile, moving rod and blades of different section (to cover the different architectural and/or structural requirements), is simple and quick to install. Assembling the blades to the uprights and connecting the moving rod to the end caps does not require step drilling; thanks to the special "T-slots" which the uprights and connecting rod are fitted with, the centre distance can be changed as needed using standard stainless steel screws. Preparation and installation operations are considerably simplified.

The ellipsoidal blades are available with rope lengths: 150 - 200 - 300* - 400* - 500* and 600* mm.

*Sections from 300 mm up to 600 mm are modular.

The orientation of the blades can be controlled manually (heavy duty pivot fork) or electrically (electric actuator). The maximum opening angle of the blades is 140°.

The fixed slat sunscreen system offers the option of achieving protection and ventilation in utility premises, stairwells or where privacy and comfort are required.

Control unit

A control unit is available for electric movement, able to control up to 4 actuators, individually and simultaneously. Optional remote and/or button control.

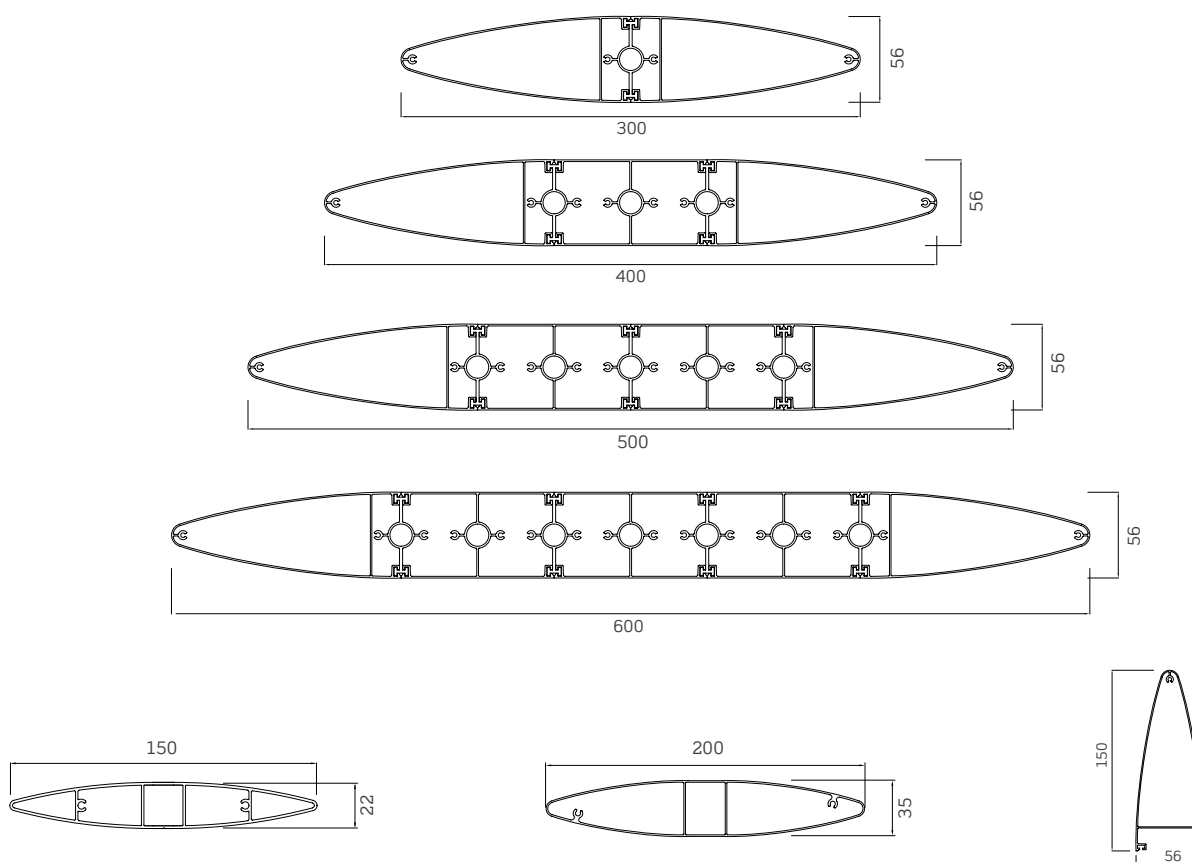

PALA FRANGISOLE/SUNSCREEN BLADE BFS0655

1351 gr/ml

Ix (mm⁴): 27426 Iy (mm⁴): 859327

Wx (mm³): 2493 Wy (mm³): 11458

PALA FRANGISOLE/SUNSCREEN BLADE BFS0002

1685 gr/ml

Ix (mm⁴): 98798 Iy (mm⁴): 2063192

Wx (mm³): 5646 Wy (mm³): 20632

BFS0222

area 582 mm²

peso/weight 1572 gr/ml

PROFILI / PROFILES

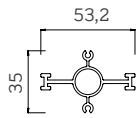

BFS0223
area 447,5 mm²
peso/weight 1208 gr/ml

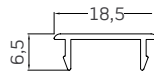

BFS0224
area 230,4 mm²
peso/weight 622 gr/ml

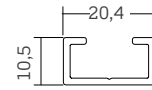

BFS0590
area 29 mm⁴
peso/weight 78 gr/ml
CARTELLINA DI COPERTURA
COVERING BOARD

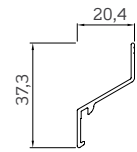

BFS0079
astina di comando
control rod
peso/weight 184 gr/ml

BFS1978
area 64,82 mm⁴
peso/weight 175 gr/ml

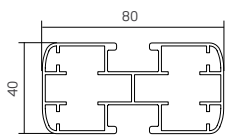

**MONTANTE / UPRIGHT
80x40 - BFS0064**
1393 gr/ml
Ix (mm⁴): 100451 Iy (mm⁴): 342789
Wx (mm³): 5023 Wy (mm³): 8570

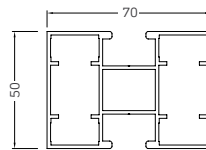

**MONTANTE / UPRIGHT
70x50 - BFS1754**
1588 gr/ml
Ix (mm⁴): 175898 Iy (mm⁴): 304104
Wx (mm³): 7036 Wy (mm³): 8689

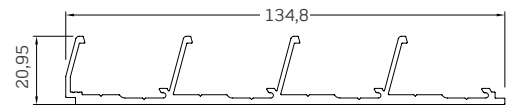

BFS1979
area 471,12 mm⁴
peso/weight 1272 gr/ml

SISTEMA FRANGISOLE A PALE FISSE FIXED BLADE SUNSCREEN SYSTEM

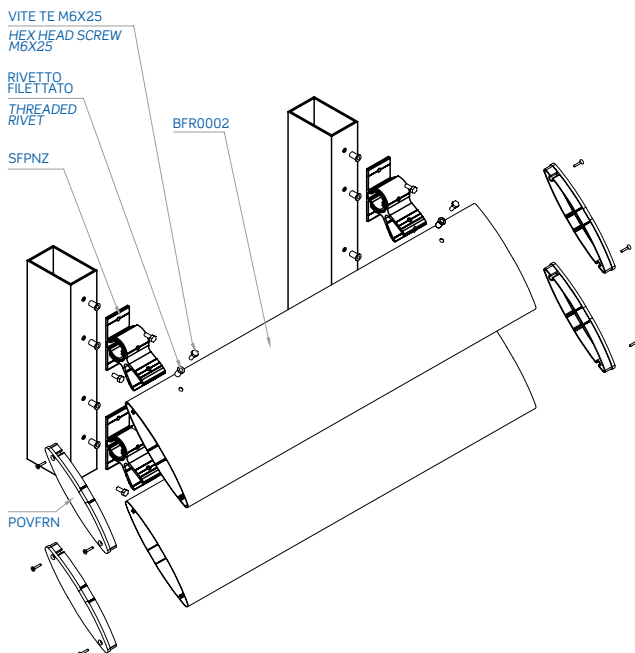

SISTEMA FISSO ORIENTAMENTO FIXED ORIENTATION SYSTEM

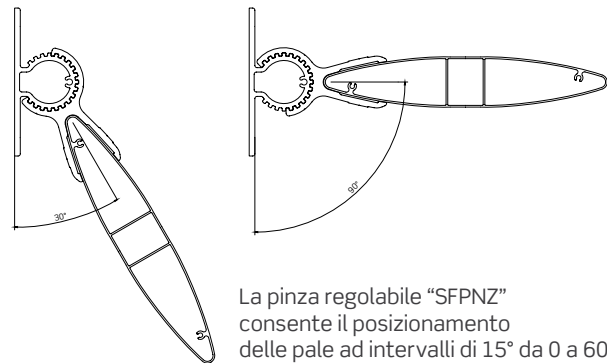

La pinza regolabile "SFPNZ" consente il posizionamento delle pale ad intervalli di 15° da 0 a 60°.
The "SFPNZ" adjustable clamp allows the blades to be positioned at 15° intervals from 0 to 60°.

ESPLOSO FRANGISOLE / SUNSCREEN EXPLODED VIEW

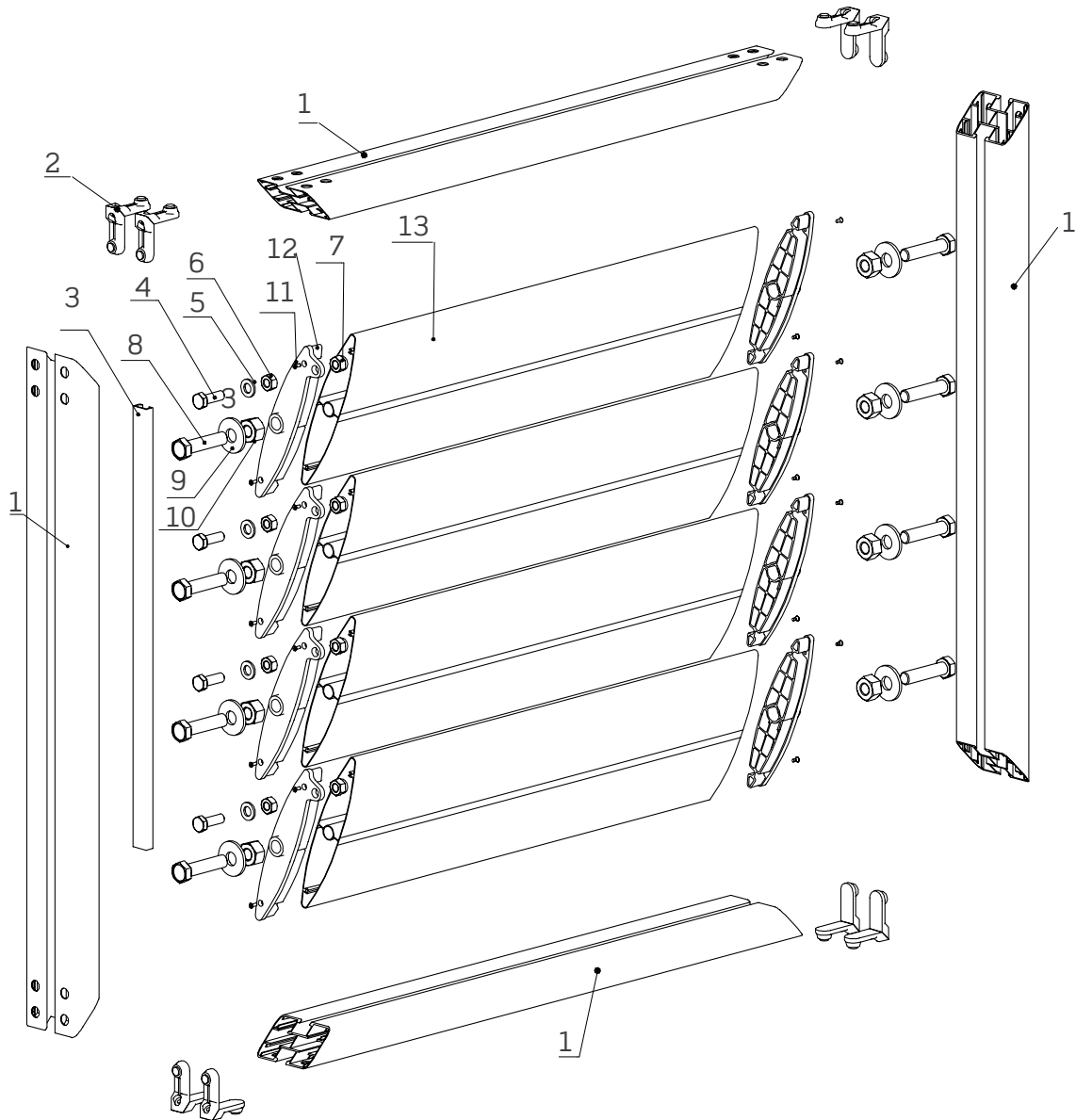

N.	Descrizione/Description	Codice/Code	Q.tà per pala Q.ty per blade
1	Telaio alluminio/Aluminium frame	BFS0064	4*
2	Squadrette 19x10,5 mm/Brackets 19x10.5 mm	SFSQ 19X10,5	8*
3	Asta di comando/Control rod	BFS0079	1*
4	Vite M10x30 TE inox A2/Hex head screw M10x30 stainless A2	SFVM10	1
5	Rosetta dentellata ø 10 inox A2/Notched washer ø 10 stainless A2	SFRD10	1
6	Dado M10 inox A2/M10 Nut stainless A2	SFDM10	1
7	Dado autobloccante inox A2/Self-locking nut stainless A2	SFDAM10	1
8	Vite TE M14x60 inox A2/Hex head screw M14x60 stainless A2	SFVM14	2
9	Rosetta ø 15x28 sp. 2,5 mm inox A2/Washer ø 15x28 th. 2.5 mm stainless A2	SFR15	2
10	Dado medio M14x60 inox A2/Medium nut M14x60 stainless A2	SFDM14	2
11	Vite testa svasata ø 4,2x19 inox A2/Countersunk head screw ø 4.2x19 stainless A2	-	4
12	Tappo in Nylon/Nylon Cap	POVFR/S	1
13	Pala frangisole/Sunscreen blade	BFS0002	-

*Quantità per telaio / *Quantity per frame

SISTEMA FRANGISOLE A LAMELLE FISSE / FIXED SLAT SUNSCREEN SYSTEM

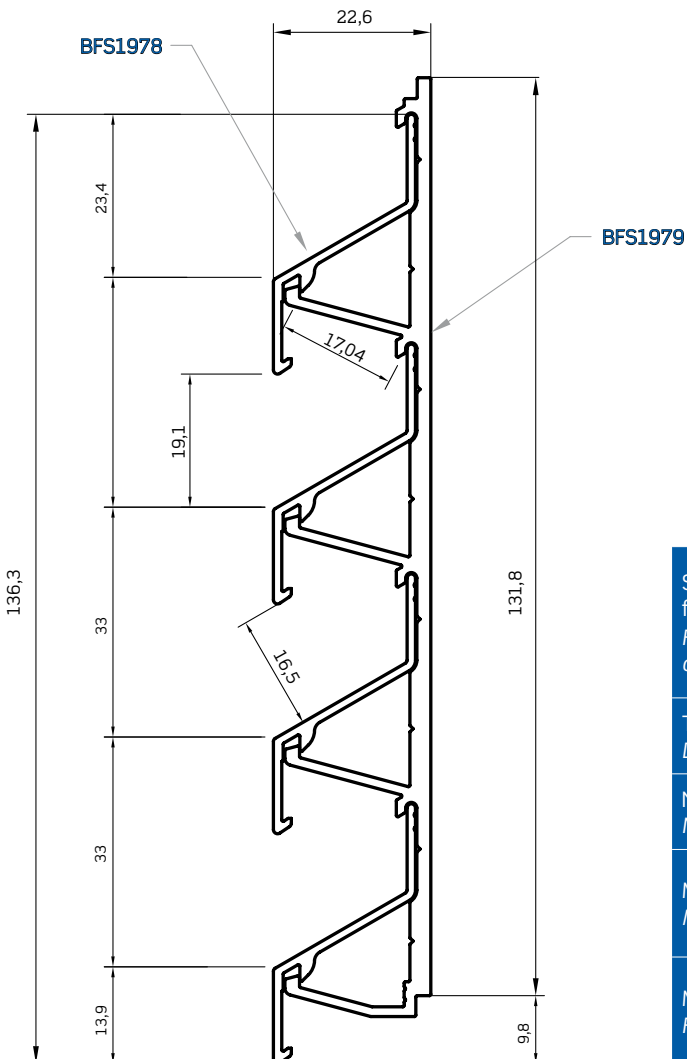
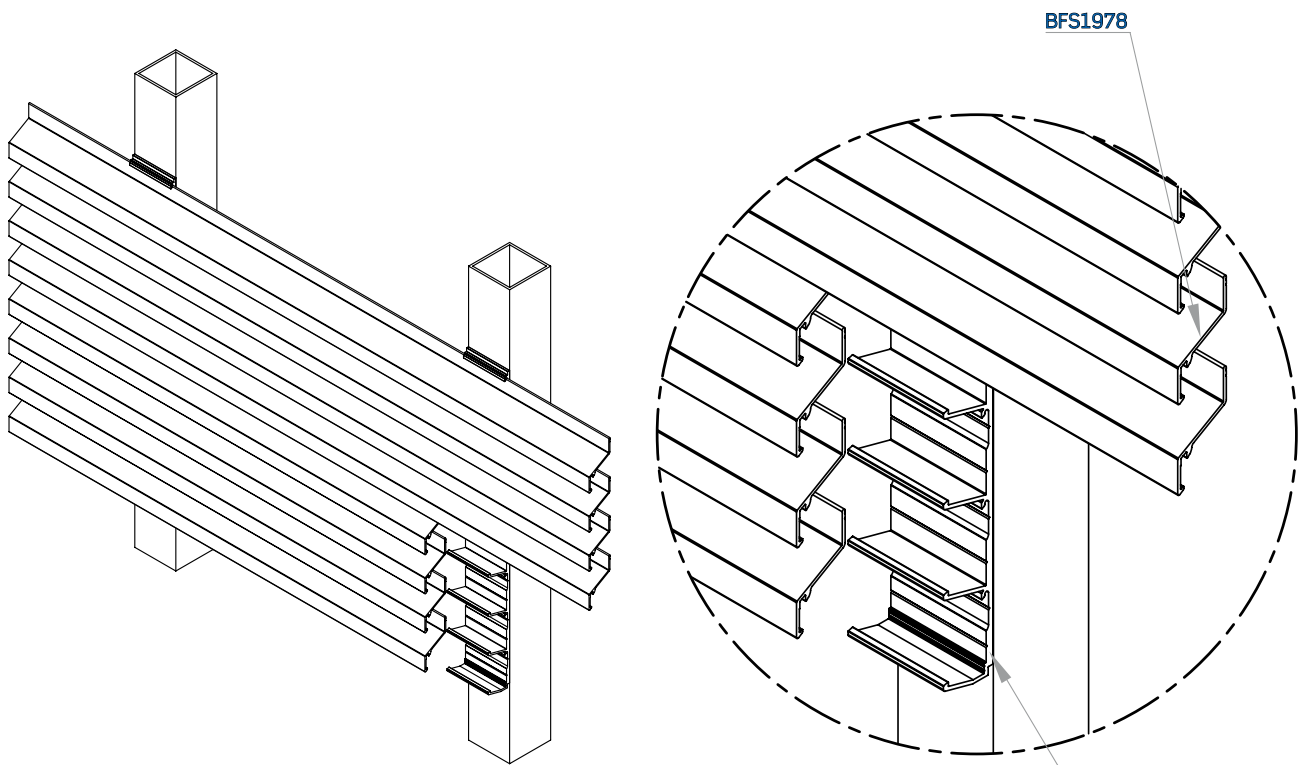

Sistema frangisole a lamelle fisse, composto da: <i>Fixed slat sunscreen system, consisting of:</i>	supporto lamella BFS1979 <i>slat support BFS1979</i>
	interasse lamella 33 mm <i>slat centre distance 33 mm</i>
Tolleranze dimensionali <i>Dimensional tolerances</i>	UNI EN 12020-2
Numero lamelle per metro <i>Number of slats per metre</i>	33
Momenti di inerzia <i>Moments of inertia</i>	Ix 5802 mm ⁴
	Iy 3939 mm ⁴
Moduli di resistenza a flessione <i>Flexural strength modules</i>	Wx 296 mm ³
	Wy 358 mm ³

SISTEMA MANUALE / MANUAL SYSTEM

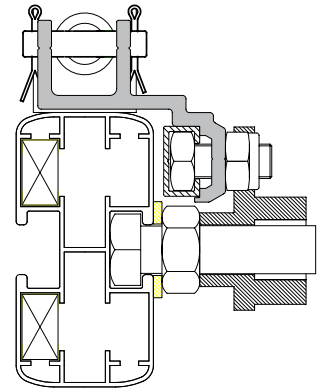
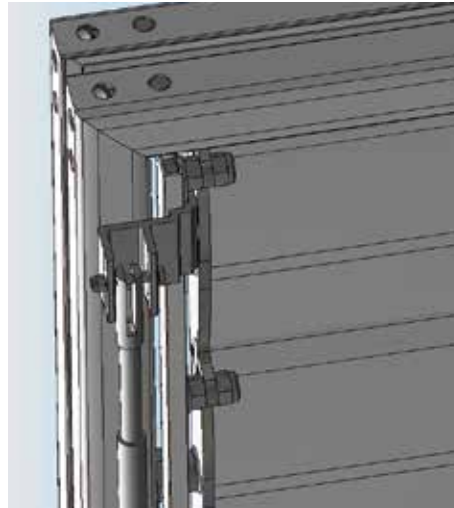
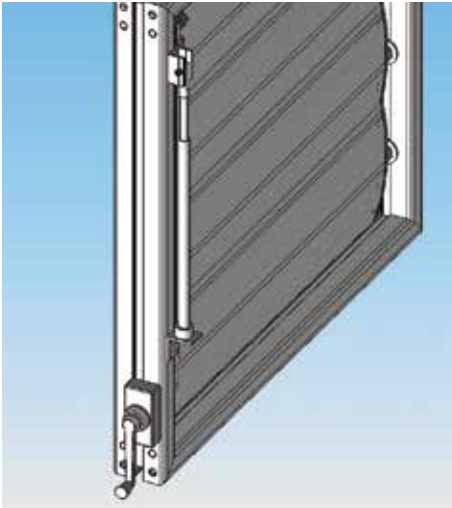

Schema di montaggio della forcella di collegamento
Assembly diagram of the connection fork

Forcella a snodo pesante / Heavy duty pivot fork

Forcella di collegamento
 Connection fork

Maniglia / Handle

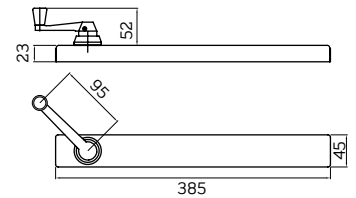
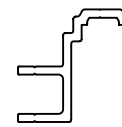
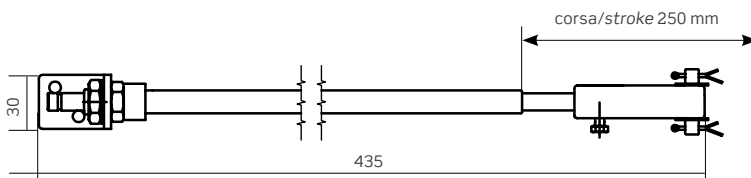

SISTEMA MOTORIZZATO / MOTORISED SYSTEM

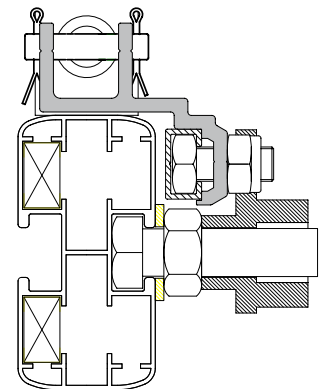
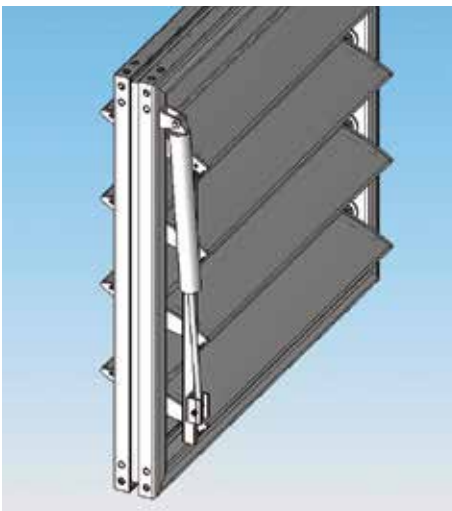





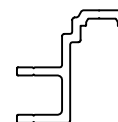
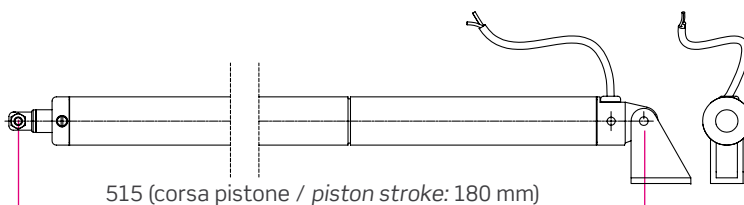

Schema di montaggio della forcella di collegamento
Assembly diagram of the connection fork

Attuatore / Actuator

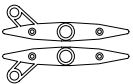
Forcella di collegamento
 Connection fork

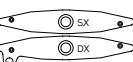



Accessori Pale / Blade Accessories

Figura / Figure	Descrizione / Description	Unità	Codice / Code
	Coppia tappi pala da 150 mm con gancio a dx e sx. Quantità: 1 coppia per pala Pair of 150 mm blade caps with RH and LH couplings. Quantity: 1 pair per blade	CP	POVFRA
	Coppia tappi pala da 200 mm con gancio a sinistra. Quantità: 1 coppia per pala Pair of 200 mm blade caps with LH coupling. Quantity: 1 pair per blade	CP	POVFRS
	Coppia Tappi pala da 200 mm con gancio a destra. Quantità: 1 coppia per pala Pair of 200 mm blade caps with RH coupling. Quantity: 1 pair per blade	CP	POVFRD
	Tappo mezza pala con aggancio a sinistra. Quantità: 1 per pala Half blade cap with LH coupling. Quantity: 1 per blade	PZ	TPOGS (aggancio a sinistra) (LH coupling)
	Tappo mezza pala con aggancio a destra. Quantità: 1 per pala Half blade cap with RH coupling. Quantity: 1 per blade	PZ	TPOGD (aggancio a destra) (RH coupling)
	Tappo mezza pala neutro. Quantità: 3 per pale da 300 / 2 per pale da 400 - 500 - 600 Neutral blade half cap. Quantity: 3 for 300 mm blades / 2 for 400 - 500 - 600 mm blades	PZ	TPOGN (neutro/neutral)
	Tappo pala centrale neutro. Quantità: pala da 400 n. 2 pezzi / pala da 500 n. 4 pezzi / pala da 600 n. 6 pezzi Neutral central blade cap. Quantity: 400 mm blade x 2 pieces / 500 mm blade x 4 pieces / 600 mm blade x 6 pieces	PZ	TPCCN (neutro/neutral)
	Distanziale. Quantità: 2 per pala Spacer. Quantity: 2 per blade	-	TPDIS

Bulloneria / Nuts and Bolts

Figura / Figure	Descrizione / Description	Q.tà per pala Q.ty per blade	Codice KIT KIT Code
	Vite TE inox M14x60 A2 Cod. SFVM14 Hex head screw stainless M14x60 A2 Code SFVM14	2	
	Rosetta inox ø 15x28 sp. 2,5 mm A2 Cod. SFR15 Washer stainless ø 15x28 th. 2.5 mm A2 Code SFR15	2	SFBM14
	Dado esagonale inox A2 Cod. SFDM14 Hex nut stainless A2 Code SFDM14	2	
	Vite TE inox M10 x 30 inox A2 Cod. SFVM10 Hex head screw stainless M10 x 30 stainless A2 Code SFVM10	1	
	Rosetta dentellata esterna ø 10,5x18 sp 2.9 mm inox A2 Cod. SFRD10 External notched washer ø 10.5x18 th. 2.9 mm stainless A2 Code SFRD10	1	SFBM10
	Dado esagonale inox A2 M10 Cod. SFDM10 Hex nut stainless A2 M10 Code SFDM10	1	
	Dado esagonale M10 autobloccante inox A2 Cod. SFDAM10 Hex nut M10 self-locking stainless A2 Code SFDAM10	1	

Accessori telaio / Frame accessories

Figura / Figure	Descrizione / Description	Unità Unit	Codice / Code
	Squadretta pressofusa 19x10,5 mm. Quantità: 8 pezzi per telaio Die-cast bracket 19x10.5 mm. Quantity: 8 pieces per frame	PZ	SFSQ 19x10.5
	Tappo montante pala. Quantità: 2 pezzi per montante Blade upright cap. Quantity: 2 pieces per upright	CP	SFTMP
	Pinza regolabile per sistema frangisole fisso per pala da 200 mm Adjustable clamp for fixed sunscreen system for 200 mm blade	PZ	SFPNZ



B.B.C.[®]
MV Line Group

B.B.C. S.p.A. - 75012 Bernalda (MT) - Italy - zona P.I.P.
Tel. 0835 544748 - 0835 549030 - Fax: 0835 549918

Divisione estrusione alluminio e verniciatura
Aluminium extrusion and powder coating
75010 Pisticci Scalo (MT) - Z.I. Comparto C
Tel. +39 0835 461058 - Fax: +39 0835 461059

www.bbcbgroup.it - info@bbcbgroup.it